

System
Make up your bathroom

System

Make up your bathroom

Design essenziale, massima funzionalità, flessibilità e libertà compositiva: scopriamo System, la nuova collezione firmata Blob pensata per arredare, con stile e personalità, il bagno contemporaneo.

Essential design, ultimate functionality, flexibility and modular freedom: this is System, the new furnishing collection by Blob designed to add style and character to modern bathrooms.

Schlichtes Design, maximale Funktionalität, Flexibilität und Gestaltungsfreiheit: all dies verkörpert System, die neue Kollektion von Blob, die entwickelt wurde, um dem modernen Badezimmer Stil und Persönlichkeit zu verleihen.

Design essentiel, fonctionnalité maximale, flexibilité et liberté de composition: voici System, la nouvelle collection de meubles de Blob conçue pour décorer, avec style et personnalité, la salle de bains contemporaine.

Diseño esencial, máxima funcionalidad, flexibilidad y libertad de composición: descubramos System, la nueva colección firmada Blob, ideada para amueblar el baño contemporáneo con estilo y personalidad.

Минимальный дизайн, максимальная функциональность, гибкость и свобода композиции. Это – System, новая коллекция мебели от Blob, разработанная для придания стиля и характера современным ванным комнатам.

Indice

Index

System significa diverse soluzioni d'arredo. Un programma caratterizzato da mobili a terra o sospesi, dalle diverse proposte lavabo e dall'ampia gamma di finiture disponibili.

The System collection offers different furnishing solutions. It features both floor-standing and suspended units, with a wide range of washbasins and a host of finishes to choose from.

System bietet unterschiedliche Einrichtungslösungen. Das Programm zeichnet sich durch bodenstehende bzw. hängende Möbel, verschiedene Waschbeckenlösungen und zahlreiche Oberflächenausführungen aus.

La collection System propose différentes solutions d'ameublement. Un projet caractérisé par des meubles à poser au sol ou suspendus, par de nombreux modèles de vasque et par une vaste gamme de finitions disponibles.

System significa distintas soluciones decorativas. Un programa caracterizado por los muebles apoyados en el suelo o suspendidos, por las diferentes propuestas de lavabos y por la amplia gama de acabados disponibles.

Коллекция System предлагает различные мебельные решения. Она включает как напольные, так и подвесные тумбы, с широким ассортиментом умывальников и различных вариантов отделки на выбор.

64-65

Finiture

Finishes / Ausführungen / Finitions
/ Acabados / Отделки

66-67

Informazioni tecniche

Technical information / Technische
informationen / Informations techniques /
Información técnica / Техническая информация

76-XX

Listino

Price list / Preisliste / Tarif / Lista de precios /
Прейскурант

system

4-5



01

10-11



02

16-17



03

22-23



04

28-29



05

34-35



06

40-41



07

46-47



08

52-53



09

58-59



10

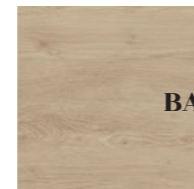

BA 993



01

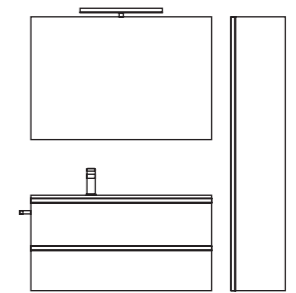

L 100 x P 46,5 cm + L 26,5 x P 25 cm

Piano con lavabo integrato
in Mineralmarmo

Un approccio rigoroso e geometrico consente la valorizzazione dello spazio attraverso un'impronta di stile sobria e moderna.

Precise, geometrical design adds a distinct touch of minimalist, modern style while also making the most of the space.

Ein strenger, geometrischer Ansatz gestattet die Aufwertung des Raums durch einen nüchternen und modernen Stil.

Une approche rigoureuse et géométrique permet de mettre en valeur l'espace avec une note distinctive de style minimaliste et moderne.

Un enfoque riguroso y geométrico permite realzar el espacio a través de un toque de estilo sobrio y moderno.

Точный геометрический дизайн позволяет расширить пространство с помощью строгого и современного стиля.



Vista prospettica della base sospesa in finitura BA 993 con maniglia a profilo in alluminio finitura cromo. Dettaglio zenitale del piano con lavabo integrato in Mineralmarmo.

Close-up of the suspended base unit shown in the BA 993 finish slim thin chrome-finish aluminium handles. Top view of the Mineralmarmo top with integrated washbasin.

Perspektivische Ansicht des Hängeschrankes in der Ausführung BA 993 mit Profilgriff in der Ausführung aus verchromtem Aluminium. Draufsicht der Platte mit integriertem Waschbecken aus Mineralmarmo.

Gros plan sur la base murale proposée dans la finition BA 993 avec la fine poignée en aluminium finition chromée. Vue de haut du plan de toilette avec vasque intégrée en Mineralmarmo.

Vista en prospecto de la base suspendida en acabado BA 993 con tirador perfilado de aluminio acabado cromo. Detalle cenital de la encimera de Mineralmarmo con lavabo integrado.

Вид в перспективе подвесной тумбы с отделкой BA 993 и хромированной ручкой-профилем. Вид сверху столешницы со встроенным умывальником из Mineralmarmo.







02

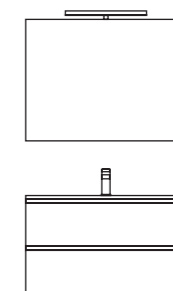

L 90 x P 46,5 cm

Piano con lavabo integrato
in Ceramica

Il colore Laccato Opaco Medioevo racconta una nuova eleganza, declinata ad una spiccata razionalità progettuale.

The matt lacquered Medioevo finish enhances a modern interpretation of elegance based on pure, rational design.

Die matte Lackausführung Medioevo zeugt von einer neuen Eleganz, die auf purem, rationalem Design basiert.

La finition Medioevo laquée mate met en valeur une interprétation moderne de l'élégance basée sur un design pur et rationnel.

El color lacado mate Medioevo evoca una nueva elegancia, declinada en una sorprendente racionalidad de diseño.

Матовая отделка Laccato Opaco Medioevo усиливает современную интерпретацию элегантности, основанную на чистом, рациональном дизайне.



Close up sulla maniglia a gola in finitura nero opaco. Dettaglio dello specchio L.90 cm e del piano con lavabo integrato in ceramica.

Close-up of the matt black grip handle. Detail of the 90cm wide mirror and the ceramic top with integrated washbasin.

Detail der Griffleiste in der matten schwarzen Lackausführung. Detail des 90 cm breiten Spiegels und der Platte mit integriertem Waschbecken aus Keramik.

Gros plan sur la prise de main intégrée dans la finition noire mate. Détail du miroir L. 90 cm et du plan de toilette avec vasque intégrée en céramique.



Close up en el tirador de gola en acabado negro mate. Detalle del espejo L.90 cm y la encimera de cerámica con lavabo integrado.

Крупный план пазов предназначенных для открывания с матовой черной отделкой. Деталь зеркала длиной 90 см и столешницы со встроенным керамическим умывальником.



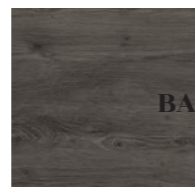

BA 992

Il monoblocco sospeso come risposta puntuale ad esigenze legate a gestione dello spazio, caratterizzazione dello stesso e comodità.

Suspended vanity units provide a prompt response to modern requirements in terms of storage space, utility and ease of use.

Der Waschtisch-Unterschrank in der Hängeausführung bietet eine zeitgemäße Antwort auf die Bedürfnisse hinsichtlich Raummanagement, Charakterisierung des Raums und Komfort.

Le monobloc mural fournit une réponse ponctuelle aux besoins en termes de gestion de l'espace, de rangement et de praticité.

El monobloque suspendido como respuesta precisa a las necesidades relacionadas con la gestión del espacio, su caracterización y comodidad.

Подвесная тумба отвечает современным требованиям к организации пространства, удобству и простоте использования.

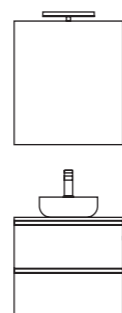

L 60 x P 46,5 cm

Piano con lavabo in appoggio "Sindy"
in Ceramica





System - 03







Laccato opaco Confetto

04

Contemporaneità perfettamente descritta dalla finitura Laccato Opaco Confetto e dalla maniglia a profilo in alluminio finitura nero. Evoluzione stilistica, funzionale e progettuale.

Matt Confetto lacquer and black finish aluminium create an eye-catching combination that is the epitome of modern design embodying the evolution of styles, functions and design.

Der hochmoderne Stil wird perfekt anhand der matten Lackausführung Confetto und des Profilgriffs in der Ausführung aus verchromtem schwarzem Aluminium deutlich. Stilistische, funktionale und gestalterische Weiterentwicklung.

La finition Confetto laquée mate et la fine poignée en aluminium dans la finition noire créent une combinaison attrayante qui est l'incarnation même du design moderne. Évolution stylistique, fonctionnelle et conceptuelle.

Contemporáneo, perfectamente descrito por el acabado lacado mate Confetto y el tirador perfilado de aluminio acabado negro. Evolución estilística, funcional y de diseño.

Матовая отделка Laccato Opaco Confetto и ручка-профиль из черного алюминия создают привлекательную комбинацию, которая является воплощением эволюции стили и функций современного дизайна.

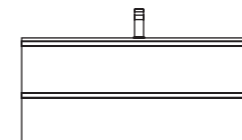
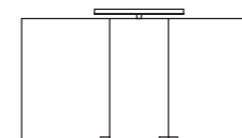

L 120 x P 46,5 cm

Piano con lavabo integrato
in Mineralsolid



System - 04



L'eleganza compositiva viene esaltata attraverso il piano con lavabo integrato in mineralsolid.

The Mineralsolid top with integrated washbasin enhances the elegance of the cabinet.

Die Eleganz der Komposition wird durch die Platte mit integriertem Waschbecken aus Mineralsolid hervorgehoben.

L'élégance de la composition est renforcée par le plan de toilette avec vasque intégrée en Mineralsolid.

La elegancia de la composición se ve reforzada por la encimera de Mineralsolid con lavabo integrado.

Столешница из Mineralsolid со встроенным умывальником придает корпусу элегантный вид.





Bianco opaco

Il bianco definisce, con estrema leggerezza, la forma compositiva. Equilibrio, funzionalità ed estetica essenziale convergono in questo nuovo concetto abitativo.

Bianco is a colour that gently defines all sorts of shapes. Balanced design, functionality and sleek beauty are the key elements of a new concept of furniture.

Bianco ist eine Farbe, die sanft jede Art von Form definiert. Gleichgewicht, Funktionalität und schlichte Ästhetik verschmelzen in diesem neuen Wohnkonzept.

Bianco est une couleur qui définit en douceur toutes sortes de formes. Équilibre, fonctionnalité et esthétique essentielle sont les éléments clés d'un nouveau concept de mobilier.

El blanco define la forma compositiva con extrema ligereza. Equilibrio, funcionalidad y estética esencial convergen en este nuevo concepto de vivienda.

Белый цвет хорошо определяет форму композиции. Сбалансированный дизайн, функциональность и изящная красота являются ключевыми элементами новой концепции мебели.

05

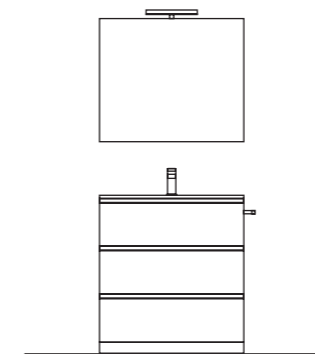

L 80 x P 46,5 cm

Piano con lavabo integrato
in Ceramica



Da ogni punto di vista si riscontrano ricerca, proporzione e praticità. Da declinare ad ogni tipologia di ambiente bagno.

Whatever the perspective, innovative design, beautiful proportions and functionality are always the key elements of any type of bathroom concept.

Aus welcher Perspektive auch immer betrachtet, sind innovatives Design, harmonische Proportionen und Funktionalität die Schlüsselemente für jede Art von Badkonzept.

Quel que soit le point de vue, un design innovant, de bonnes proportions et la fonctionnalité sont toujours les éléments clés de tout type de salle de bains.

Desde cada punto de vista se manifiesta investigación, proporción y practicidad. Para aplicar en cualquier tipo de cuarto de baño.

Независимо от перспективы, инновационный дизайн, красивые пропорции и функциональность всегда являются ключевыми элементами любого типа концепции ванной комнаты.





06

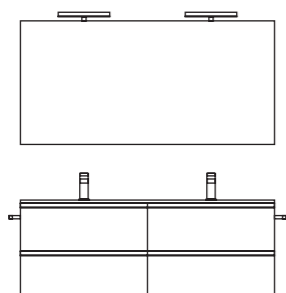

L 140 x P 46,5 cm

Piano con lavabo integrato
in Ceramica

Nuove prospettive celebrano suggerimenti
d'arredo pensati per soddisfare ogni tipologia
di esigenza. Tra ispirazione e razionalità.

*New perspectives highlight furnishing solutions
designed to meet new tastes and requirements
with a combination of inspiration and rationality.*

*Neue Perspektiven bieten
Einrichtungsvorschläge, die jedem
Bedürfnis gerecht werden. Eine Mischung
aus Inspiration und Rationalität.*

*De nouvelles perspectives célèbrent les
suggestions d'ameublement conçues pour
satisfaire tous types de besoin avec une
combinaison d'inspiration et de rationalité.*

*Las nuevas perspectivas celebran las
sugerencias de mobiliario diseñadas
para satisfacer todo tipo de necesidades.
Entre inspiración y racionalidad.*

*Новые перспективы подчеркивают
мебельные решения, разработанные
для удовлетворения потребностей и
вкусов потребителей – что-то между
вдохновением и рациональностью.*

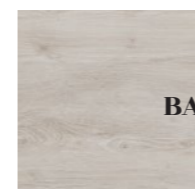

BA 991





Vista zenitale del piano con doppio lavabo integrato in ceramica. Close up sull'abbinamento ricercato della finitura BA 991 con la maniglia a profilo in alluminio finitura nero.

Top view of the ceramic top with two integrated washbasins. Close-up of the BA 991 finish beautifully enhanced by the slim black finish aluminium handle.

Draufsicht der Platte mit doppeltem integriertem Waschbecken aus Keramik. Detail der raffinierten Kombination zwischen dem BA 991-Finish und dem Profilgriff in der Ausführung aus schwarzem Aluminium.

Vue de haut du plan de toilette avec double vasque intégrée en céramique. Gros plan sur l'association raffinée de la finition BA 991 avec la fine poignée en aluminium dans la finition noire.

Vista cenital de la encimera de cerámica con doble lavabo integrado. Close up de la refinada combinación del acabado BA 991 con el tirador perfilado de aluminio en acabado negro.

Вид сверху столешницы со встроенными парными умывальниками из керамики. Вид сверху отделки BA 991 с ручкой-профилем из черного алюминия.



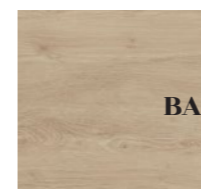

BA 993

07

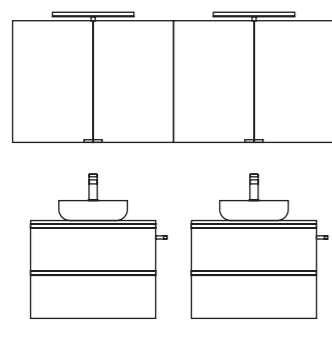

L 70+70 x P 46,5 cm

Piani con lavabi in appoggio "Sindy"
in Ceramica

Parallellismi e volumi a contrasto: alle forme pure dei mobili sospesi e dei pensili a specchio fanno da contraltare le linee sinuose dei lavabi.

Parallel lines and contrasting volumes: the pure shapes of the suspended cabinets and mirrored wall cabinets go hand in hand with the gentle curves of the washbasins.

Parallele Linien und kontrastierende Volumen: die schlichten Formen der Hängemöbel und der verspiegelten Oberschränke gehen Hand in Hand mit den sanften Rundungen der Waschbecken.

Parallélismes et volumes contrastés: les formes épurées des meubles suspendus et des armoires murales à miroir se mêlent aux lignes sinueuses des vasques.

Paralelismos y volúmenes contrastantes: las formas puras de los muebles suspendidos y de los muebles altos con espejo se ven contrarrestadas por las líneas sinuosas de los lavabos.

Параллельные линии и контрастные объемы: чистые формы подвесных тумб и зеркальных настенных шкафов идут рука об руку с мягкими изгибами раковин.





System - 07





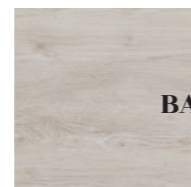

BA 991

Scoprire delle composizioni che, nella loro compattezza, abbinano capacità contenitiva e armonia di tipo estetico.

Our furnishing combinations are compact, yet offer plenty of storage space and harmonious design.

Unsere Einrichtungskombinationen sind kompakt, bieten dennoch viel Stauraum und ein harmonisches Design.

Découvrir des compositions qui sont compactes, tout en offrant beaucoup d'espace de rangement et un design harmonieux.

Descubrir las composiciones compactas que se armonizan con la capacidad de contención y la armonía estética.

Откройте для себя композиции, которые по своей компактности сочетают в себе вместительность и гармоничный дизайн.

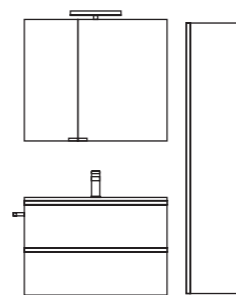

L 80 x P 39,5 cm + L 26,5 x P 25 cm

Piano con lavabo integrato
in Ceramica





La colonna è caratterizzata da una suddivisione composta da ripiani in vetro. Il piano presenta il lavabo integrato in Ceramica.

The storage space of this tall unit is separated by elegant glass shelves. Ceramic top with integrated washbasin.

Dieser Hochschrank zeichnet sich durch elegante Glasböden aus. Die Platte ist mit einem integrierten Waschbecken aus Keramik ausgestattet.

La colonne est caractérisée par une subdivision composée d'étagères en verre. Le plan de toilette avec vasque intégrée est en céramique.

La columna se caracteriza por una subdivisión compuesta por estantes de vidrio. La encimera de cerámica tiene un lavabo integrado.

Колонка характеризуется подразделением, состоящим из стеклянных полок. Столешница включает встроенный умывальник из керамики.





Laccato opaco
Noce Moscata

Colori eleganti e desaturi tracciano le tendenze dell'arredo bagno. Soluzioni contenute, proporzionate e ricercate in ogni loro dettaglio.

Pale, elegant colours dictate modern trends in bathroom furniture. Perfectly balanced, compact solutions meticulously designed down to the smallest detail.

Entsättigte, elegante Farben bestimmen die modernen Trends der Badmöbel. Perfekt ausbalancierte, kompakte Lösungen, die bis ins kleinste Detail durchdacht sind.

Des couleurs pâles et élégantes dictent les tendances en matière d'ameublement de salle de bains. Des solutions contenues, proportionnées et recherchées dans les moindres détails.

Los colores elegantes y desaturados marcan las tendencias decorativas de los cuartos de baño. Soluciones contenidas, proporcionadas y refinadas en cada detalle.

Эlegantные и ненасыщенные цвета прослеживают тенденции по обустройству интерьера ванной комнаты. Идеально сбалансированные, компактные решения, тщательно продуманные до мельчайших деталей.

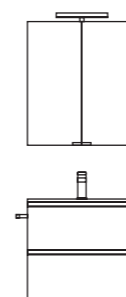

L 60 x P 46,5 cm

Piano con lavabo integrato
in Mineralsolid

09



Elemento caratterizzante il pensile a specchio bifacciale. I cassetti possono essere attrezzati per razionalizzare la suddivisione interna.

The double-sided mirror is the distinguishing element of this wall cabinet. We have designed special partitions and accessories to help you make the most of the storage space inside the drawers.

Der doppelseitige Spiegel ist das Erkennungsmerkmal dieses Wandschranks. Wir haben spezielle Trennwände und Zubehörteile entwickelt, um den Stauraum in den Schubladen optimal zu nutzen.

Le miroir double face est l'élément distinctif de cette armoire murale. Les tiroirs peuvent être équipés de séparateurs pour rationaliser la division interne.

Elemento característico del mueble alto con espejo de doble cara. Los cajones pueden ser equipados para racionalizar la compartimentación interna.

Двустороннее зеркало является отличительным элементом этого настенного шкафа. Ящики могут быть оборудованы отделениями для рационального хранения вещей.



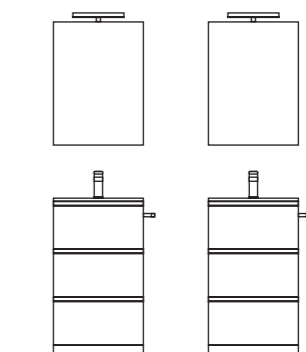

L 50+50 x P 38,5 cm

Piani con lavabi integrati
in Ceramica

Soluzioni a terra compatte, rese preziose da dettagli capaci di fare la differenza. Il Laccato Lucido Rossetto rimanda a concetti legati allo stile e all'inedito.

Compact floor-standing solutions enriched by details that can really make a difference. The glossy Rossetto lacquered finish evokes unexpected style.

Kompakte bodenstehende Lösungen, angereichert mit Details, die einen Unterschied machen können. Die glänzende Lackausführung Rossetto zeugt von einem unerwarteten Stil.

Des solutions posées au sol compactes, enrichies par des détails capables de faire la différence. La finition Rossetto laquée brillante évoque des concepts liés à un style inédit.

Soluciones apoyadas en el suelo, compactas, embellecidas por detalles que marcan la diferencia. El lacado brillo Rossetto hace referencia a conceptos relacionados con el estilo y la novedad.

Компактные напольные решения, обогащенные функциональными деталями. Отделка Laccato Lucido Rossetto создает неожиданный эффект в оформлении интерьера ванной комнаты.



System - 10

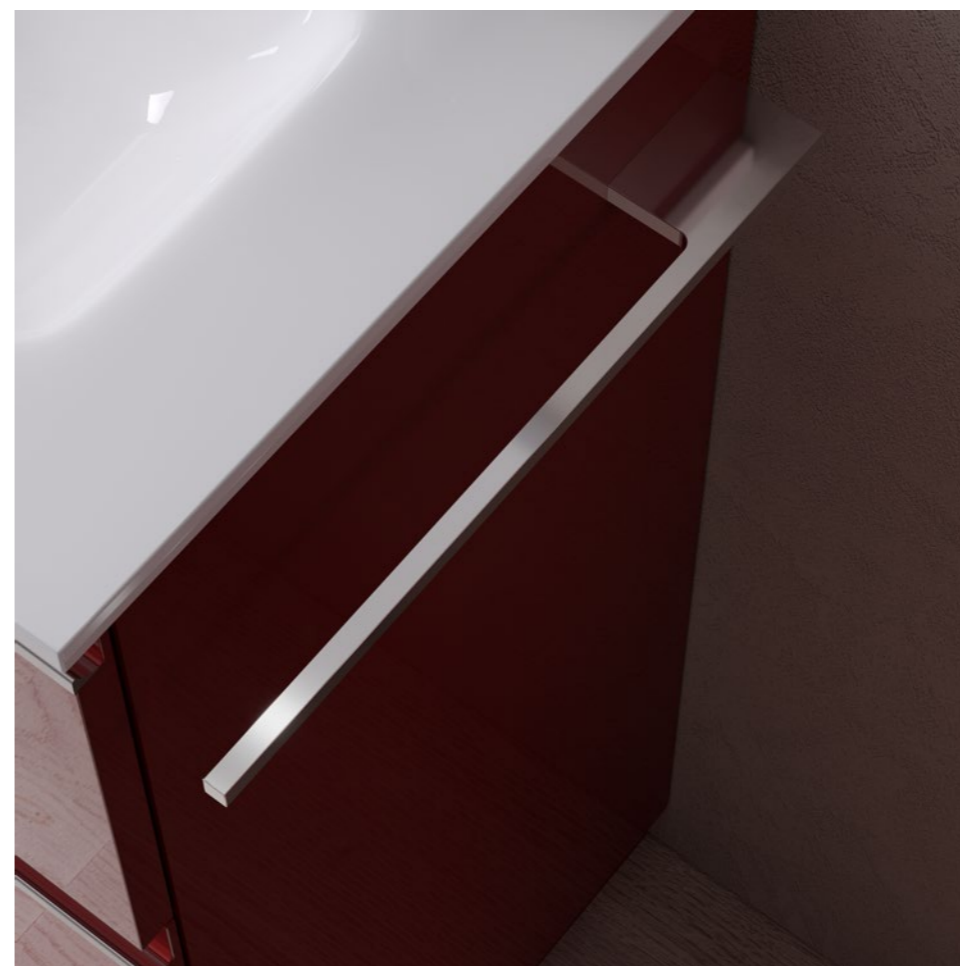

La profondità ridotta della base consente un'ottimizzazione dello spazio. Il portasciugamani è in finitura cromo come la maniglia a profilo.

This practical base unit has a reduced depth to help you make the most of the space in the bathroom. Chrome-finish towel rail and slim handle.

Der praktische Unterschrank zeichnet sich durch eine reduzierte Tiefe aus, um den Raum im Badezimmer optimal zu nutzen. Handtuchhalter und Profilgriff in der verchromten Ausführung.

La profondeur réduite de la base permet d'optimiser l'espace. Le porte-serviettes est proposé dans la finition chromée tout comme la fine poignée.

La reducida profundidad de la base permite optimizar el espacio. El toallero presenta acabado cromo como el tirador perfilado.

Уменьшенная глубина тумбы позволяет оптимизировать пространство. Держатель для полотенец с хромированной отделкой, как и ручка-профиль.

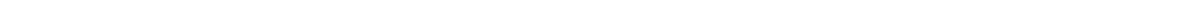

Finiture

Finishes / Ausführungen / Finitions
/ Acabados / Отделки

Essenze

Woods
Holzarten
Finitions
Maderas
Породы
древесины



BA 991



BA 993



BA 992

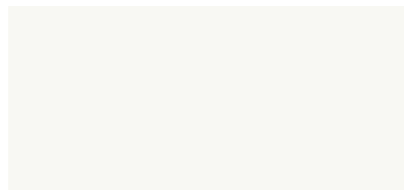

Bianco Opaco

Laccati metal color opachi

Matt Metal Lacquers
Matte Lackausführungen Metal
Laqués Metal mats
Lacados Metal mate
Лакированная матовая
отделка металла



Oro



Rame

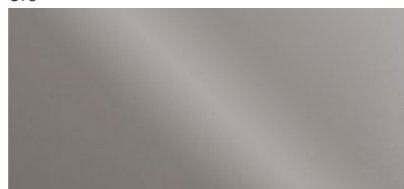

Titanio



Bianco Perlato

Laccati opachi, lucidi, soft touch

Matt, gloss lacquered and soft touch colours
Glänzenden lackierte farben und Soft Touch
Laques mats, brillants et soft touch
Lacados opacos, brillos y soft touch
Лакированная матовая отделка,
глянцевая и Soft Touch

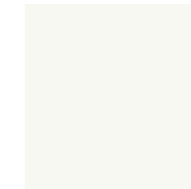

Bianco



Perla



Sahara



Beige Avorio



Senape



Malto



Giallo Bikini

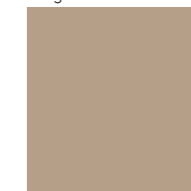

Biscotto



Cappuccino



Tortora



Marrone Terra



Verde Salvia



Verde Canna



Verde Bluastro



Blu Acciaio



Petrolio



Azzurro India



Verde Marino



Blu Pastello



Cobalto



Curacao



Rosso Arancio



Rosso Giamaica



Rossetto



Rosso Cuoio



Rosso Scuro



Grigio Viola



Orchidea

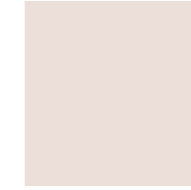

Diva



Confetto



Noce Moscata



Medioevo



Grigio Cenere



Grigio Seta



Grigio Nuvola



Polvere



Grigio Pietra

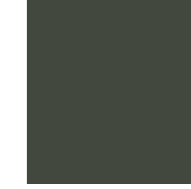

Grigio Londra



Grigio Traffico



Marrone Grigio



Nero

Informazioni tecniche

Technical information / Technische Informationen / Informations techniques / Información técnica / Техническая информация

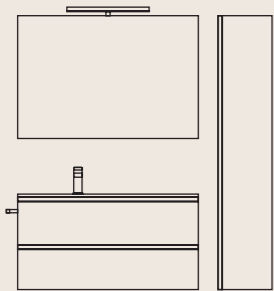

L 100 x P 46,5 cm + L 26,5 x P 25 cm

4-5
01

Base	L 100 x H 53,5 x P 45,5 cm	BA 993
Piano con lavabo integrato sx	L 100 x P 46,5 x SP 1,5 cm	Mineralmarmo
Colonna	L 26,5 x H 160 x P 25 cm	BA 993
Specchio	L 100 x H 70 cm	---
Faretto	L 50 cm	---

EN. BA 993 finish base and tall unit. Mineralmarmo top with integrated washbasin. / DE. Unter- und Hochschrank in der Ausführung BA 993. Platte mit integriertem Waschbecken aus Mineralmarmo. / FR. Base et colonne dans la finition BA 993. Plan de toilette avec vasque intégrée en Mineralmarmo. / ES. Base y columna en acabado BA 993. Encimera de Mineralmarmo con lavabo integrado. / RU. Тумба и колонка с отделкой BA 993. Столешница со встроенным умывальником из Mineralmarmo.

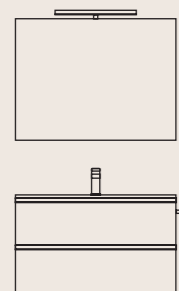

L 90 x P 46,5 cm

10-11
02

Base	L 90 x H 53,5 x P 45,5 cm	Laccato opaco Medioevo
Piano con lavabo integrato	L 91 x P 46,5 x SP 2 cm	Ceramica
Specchio	L 90 x H 70 cm	---
Faretto	L 50 cm	---

EN. Matt Medioevo lacquered base unit. Ceramic top with integrated washbasin. / DE. Unterschrank in der matten Lackausführung Medioevo. Platte mit integriertem Waschbecken aus Keramik. / FR. Base dans la finition Medioevo laquée mate. Plan de toilette avec vasque intégrée en céramique. / ES. Base de lacado mate Medioevo. Encimera de cerámica con lavabo integrado. / RU. Тумба с матовой отделкой Laccato opaco Medioevo. Столешница со встроенным умывальником из керамики.

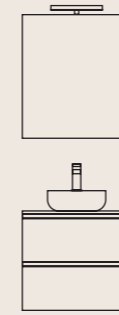

L 60 x P 46,5 cm

16-17
03

Base	L 60 x H 53,5 x P 45,5 cm	BA 992
Piano	L 60 x P 46,5 x SP 1,2 cm	BA 992
Lavabo "Sindy"	Ø 40 x H 11,5 cm	Ceramica
Specchio	L 60 x H 70 cm	---
Faretto	L 30 cm	---

EN. BA 992 finish base unit and top. Ceramic countertop washbasin. / DE. Unterschrank und Platte in der Ausführung BA 992. Aufsatzwaschbecken aus Keramik. / FR. Base et plan de toilette dans la finition BA 992. Vasque à poser en céramique. / ES. Base y encimera en acabado BA 992. Lavabo de cerámica en arayo. / RU. Тумба и столешница с отделкой BA 992. Настольный умывальник из керамики.

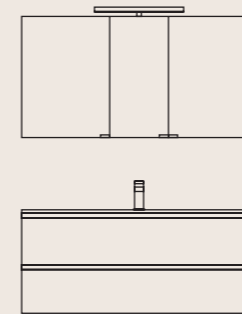

L 120 x P 46,5 cm

22-23
04

Base	L 120 x H 53,5 x P 45,5 cm	Laccato opaco Confetto
Piano con lavabo integrato cx	L 120 x P 46,5 x SP 1,5 cm	Mineralsolid
Specchio contenitivo	L 120 x H 70 x P 16,6 cm	---
Faretto	L 50 cm	---

EN. Matt Confetto lacquered base unit. Mineralsolid top with integrated washbasin. Storage mirror. / DE. Unterschrank in der matten Lackausführung Confetto. Platte mit integriertem Waschbecken aus Mineralsolid. Spiegelschrank. / FR. Base dans la finition Confetto laquée mate. Plan de toilette avec vasque intégrée en Mineralsolid. Miroir armoire. / ES. Base de lacado mate Confetto. Encimera de Mineralsolid con lavabo integrado. Espejo para guardar. / RU. Тумба с матовой отделкой Laccato opaco Confetto. Столешница со встроенным умывальником из Mineralsolid. Зеркало для хранения.

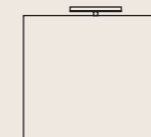

L 80 x P 46,5 cm

28-29
05

Base	L 80 x H 80+6 x P 45,5 cm	Bianco opaco
Piano con lavabo integrato	L 81 x P 46,5 x SP 2 cm	Ceramica
Specchio	L 80 x H 70 cm	---
Faretto	L 30 cm	---

EN. Matt Bianco finish base unit. Ceramic top with integrated washbasin. / DE. Unterschrank in der matten Ausführung Bianco. Platte mit integriertem Waschbecken aus Keramik. / FR. Base dans la finition Bianco mat. Plan de toilette avec vasque intégrée en céramique. / ES. Base en acabado Bianco mate. Encimera de cerámica con lavabo integrado. / RU. Тумба с матовой отделкой Bianco opaco. Столешница со встроенным умывальником из керамики.

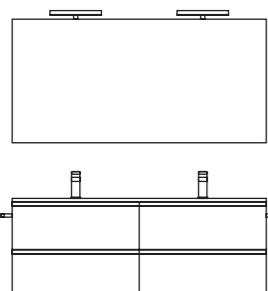

L 70+70 x P 46,5 cm

34-35

06

Base	L 70+70 x P 45,5 cm	BA 991
Piano con lavabo integrato	L 141 x P 46,5 x SP 2 cm	Ceramica
Specchio	L 140 x H 70 cm	---
Faretto	L 30 cm	---

EN. BA 991 finish base units. Ceramic top with integrated washbasin. / DE. Unterschranke in der Ausführung BA 991. Platte mit integriertem Waschbecken aus Keramik. / FR. Bases dans la finition BA 991. Plan de toilette avec vasque intégrée en céramique. / ES. Bases en acabado BA 991. Encimera de cerámica con lavabo integrado. / RU. Тумбы с отделкой BA 991. Столешница со встроенным умывальником из керамики.

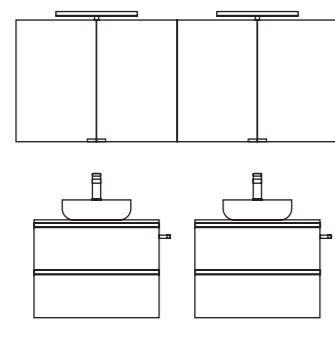

L 70+70 x P 46,5 cm

40-41

07

Base (n. 2)	L 70 x H 53,5 x P 45,5 cm	BA 993
Piano	L 70 x P 46,5 x SP 1,2 cm	BA 993
Lavabi "Sindy"	Ø 40 x H 11,5 cm	Ceramica
Specchi contenitivi	L 90+90 x H 70 x P 16,6 cm	---
Faretto	L 50 cm	---

EN. BA 993 finish base units and tops. Ceramic countertop washbasins. Storage mirrors. / DE. Unterschranke und Platten in der Ausführung BA 993. Aufsatzwaschbecken aus Keramik. Spiegelschränke. / FR. Bases et plans de toilette dans la finition BA 993. Vasques à poser en céramique. Armoires miroirs. / ES. Base y encimera en acabado BA 993. Lavabo de cerámica en arojo. Espejos para guardar. / RU. Тумбы и столешницы с отделкой BA 993. Настольные умывальники из керамики. Зеркало для хранения.

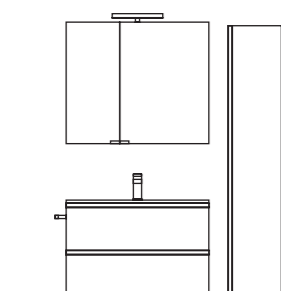

L 80 x P 39,5 cm + L 26,5 x P 25 cm

46-47

08

Base	L 80 x H 53,5 x P 38,5 cm	BA 991
Piano con lavabo integrato	L 81 x P 39,5 x SP 2 cm	Ceramica
Colonna	L 26,5 x H 160 x P 25 cm	BA 991
Specchio contenitivo	L 80 x H 70 x P 16,6 cm	---
Faretto	L 30 cm	---

EN. BA 991 finish base and tall unit. Ceramic top with integrated washbasin. Storage mirror. / DE. Unter- und Hochschrank in der Ausführung BA 991. Platte mit integriertem Waschbecken aus Keramik. Spiegelschrank. / FR. Base et colonne dans la finition BA 991. Plan de toilette avec vasque intégrée en céramique. Miroir armoire. / ES. Base y columna en acabado BA 991. Encimera de cerámica con lavabo integrado. Espejo para guardar. / RU. Тумба и колонка с отделкой BA 991. Столешница со встроенным умывальником из керамики. Зеркало для хранения.

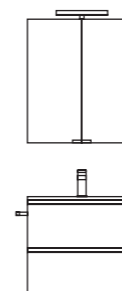

L 60 x P 46,5 cm

52-53

09

Base	L 60 x H 53,5 x P 45,5 cm	Laccato opaco Noce Moscata
Piano con lavabo integrato	L 60 x P 46,5 x SP 1,5 cm	Mineralsolid
Specchio contenitivo	L 60 x H 70 x P 16,6 cm	---
Faretto	L 30 cm	---

EN. Matt Noce Moscata lacquered base unit. Mineralsolid top with integrated washbasin. Storage mirror. / DE. Unterschrank in der matten Lackausführung Noce Moscata. Platte mit integriertem Waschbecken aus Mineralsolid. Spiegelschrank. / FR. Base dans la finition Moscata laquée mate. Plan de toilette avec vasque intégrée en Mineralsolid. Miroir armoire. / ES. Base de lacado mate Noce Moscata. Encimera de Mineralsolid con lavabo integrado. Espejo para guardar. / RU. Тумба с отделкой Laccato opaco Noce Moscata. Столешница со встроенным умывальником из Mineralsolid. Зеркало для хранения.

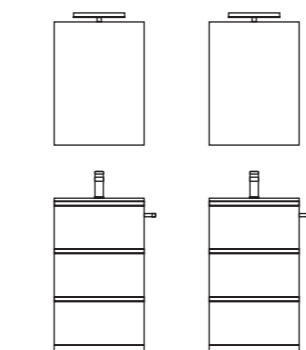

L 50+50 x P 38,5 cm

58-59

10

Base (n.2)	L 50 x H 80+6 x P 38,5 cm	Laccato lucido Rossetto
Piano con lavabo integrato	L 51 x P 39,5 x SP 2 cm	Ceramica
Specchio	L 50 x H 70 cm	---
Faretto	L 30 cm	---

EN. Glossy Rossetto lacquered base units. Ceramic top with integrated washbasin. / DE. Unterschranke in der glänzenden Lackausführung Rossetto. Platte mit integriertem Waschbecken aus Keramik. / FR. Bases dans la finition Rossetto laquée brillante. Plan de toilette avec vasque intégrée en céramique. / ES. Bases de lacado brillo Rossetto. Encimera de cerámica con lavabo integrado. / RU. Тумбы с отделкой Laccato lucido Rossetto. Столешница со встроенным умывальником из керамики.

ITALIAN DESIGN

Ogni "prodotto" ideagRoup viene realizzato in Italia ma ciò che lo rende un esempio di made in Italy per eccellenza (al 100%) sono i suoi valori: la creatività, la tradizione nel mondo del mobile che risale al 1987 e la qualità, caratteristica naturale per un'azienda che si confronta giornalmente con il proprio pubblico e le sue esigenze. Tutto ciò si traduce in un'esperienza e in un know-how specifici.

All IDEAGROUP "products" are manufactured in Italy. Their unique values turn them into excellent examples of 100% Italian style: creativity, a long cabinetmaking tradition since 1987 and quality, which is a natural characteristic of a company that caters for its customers' needs on a daily basis. All of this translates into specific experience and know-how.

Jedes "produkt" von ideagRoup wird in Italien angefertigt, aber es sind seine Werte, die es zu einem gelungenen Beispiel des "made in Italy" (zu 100%) machen: die Kreativität, die Tradition in der Möbelwelt, die auf das Jahr 1987 zurückgeht, und die Qualität, eine natürliche Eigenschaft für einen Betrieb, der sich täglich mit den Kunden und deren Bedürfnissen auseinandersetzt. All das zeugt von einer eingehenden Erfahrung und einem spezifischen Know-how.

Chaque «produit» ideagRoup est réalisé en Italie, mais plus que cela, ce qui en fait un excellent exemple de style 100% made in Italy ce sont ses valeurs: la créativité, la tradition comme producteur de meubles depuis 1987 et la qualité, caractéristique naturelle pour une entreprise qui se mesure quotidiennement avec son public et ses exigences. Tout cela se traduit dans une expérience et dans un savoir-faire spécifiques.

Cada "producto" ideagRoup viene fabricado en Italia, pero lo que la convierte en un ejemplo de made in Italy por excelencia (al 100%) son sus valores: la creatividad, la tradición en el mundo del mueble que nos remonta al 1987 y la calidad, característica natural de una empresa que se confronta diariamente con el propio público y sus exigencias. Todo ello se traduce en una experiencia y en un know-how específico.

EUROPEAN MATERIALS

I materiali che compongono i nostri prodotti provengono esclusivamente dal mercato comune europeo.

Our products are made exclusively with materials sourced in the European Union.

Die Materialien, mit denen unsere Produkte angefertigt wurden, stammen ausschließlich aus dem europäischen Binnenmarkt.

Les matériaux qui composent nos produits proviennent exclusivement de l'Union européenne.

Los materiales que componen nuestros productos provienen exclusivamente del mercado común europeo.



È un pannello di tipo truciolare nel quale viene impiegato solo legno riciclato, con materiali ecocompatibili. È dotato di notevole solidità, compattezza, indeformabilità e resistenza.

This is a type of particleboard panel which is made of recycled wood and environment-friendly materials. It is remarkably solid, does not deform, and is durable.

Es handelt sich um eine Spanplatte, für deren Anfertigung ausschließlich recyceltes Holz, d.h. umweltfreundliche Materialien, verwendet wird. Sie ist besonders stabil, kompakt, unverformbar und widerstandsfähig.

C'est un panneau de particules de bois dans lequel est utilisé uniquement du bois recyclé, avec des matériaux écocompatibles. Il est caractérisé par une remarquable solidité, compacité, indéformabilité et résistance.

Es un panel de tipo aglomerado en el que se emplea únicamente madera reciclada, con materiales ecocompatibles. Indeflexible y compacto, dotado de una notable solidez y resistencia.

System

CATAS

Catas è il punto di riferimento in Italia per le prove di laboratorio in questo settore e certifica il prodotto in base alle normative tecniche italiane, europee e internazionali per quanto riguarda la resistenza meccanica, le prove reazione fuoco, la sicurezza arredamento, l'emissione formaldeide, l'analisi difetti legno e molto altro ancora.

Catas is a reference research centre and laboratory for furniture companies in Italy, which certifies products according to Italian, European and international technical regulations with reference to mechanical resistance, fire reaction, safety, formaldehyde emissions, wood defect analyses and much more.

Catas ist der Bezugspunkt in Italien für die Laborprüfungen in diesem Sektor und zertifiziert das Produkt auf der Grundlage der italienischen, europäischen und internationalen technischen Vorschriften im Zusammenhang mit der mechanischen Festigkeit, der Prüfungen der Feuerbeständigkeit, der Sicherheit, der Formaldehydemission, der Analyse von Holzdefekten usw.

Catas est le centre de recherche et laboratoire de référence en Italie pour l'industrie du meuble, qui certifie le produit conformément aux réglementations techniques italiennes, européennes et internationales en ce qui concerne la résistance mécanique, les essais de réaction au feu, la sécurité des meubles, l'émission de formaldéhyde, l'analyse des défauts du bois et beaucoup plus encore.

Catas es el punto de referencia en Italia para las pruebas de laboratorio en este sector y certifica el producto en base a las normativas técnicas italianas, europeas e internacionales por lo que concierne la resistencia mecánica, las pruebas a reacción del fuego, la seguridad en la decoración, la emisión formaldehído, el análisis defectos de madera, y mucho más.

MDF

Mdf: sigla di medium density fiberboard, ovvero "pannello a media densità". Dalle ottime caratteristiche meccaniche, molto stabile e compatto, questo pannello è in grado di offrire una buona resistenza all'umidità, con minima emissione di formaldeide.

Abbreviation for medium density fibreboard. It offers exceptional mechanical characteristics and is very stable and solid. This panel offers excellent resistance to moisture, with minimal emissions of formaldehyde.

Mdf: abkürzung für medium density fiberboard, d.h. "mitteldichte holzfaserplatte". Diese Platte, die hervorragende mechanische Eigenschaften aufweist und sehr stabil und kompakt ist, ist besonders wasserfest und zeichnet sich durch minimale formaldehydemissionen aus.

Mdf: abréviation de medium density fiberboard, à savoir «panneau de fibres à densité moyenne». Il présente des caractéristiques mécaniques optimales et est très stable et solide. Le panneau est en mesure d'offrir une bonne résistance contre l'humidité, avec une émission minimale de formaldéhyde.

Mdf: sigla de medium density fiberboard, ó bien "panel a media densidad". De óptimas características mecánicas, muy estable y compacto, este panel está en grado de ofrecer una buena resistencia a la humedad, con mínima emisión de formaldehído.



CREDITS:

Blob

System - Make up your bathroom (Marzo 2020)

Design+AD: Ideagroup

Concept: Neiko

Images: Neiko

Printed in Italy by: Grafiche Antiga

Blob si riserva la facoltà di modificare, in qualunque momento e senza preavviso le caratteristiche tecniche degli elementi illustrati nel presente catalogo. Declina ogni responsabilità per eventuali inesattezze contenute nello stesso.

Blob reserves the right to modify the technical characteristics of the elements contained in this catalogue without notice and shall not be liable for any inexactness contained herein.

Blob behält sich das Recht vor, die technischen Eigenschaften der im vorliegenden Katalog abgebildeten Elemente jederzeit und ohne Vorbescheid zu ändern. Man lehnt jede Haftung für eventuelle im Katalog enthaltene Fehler ab.

Blob se réserve la faculté de modifier, dans tout moment et sans avis préalable, les caractéristiques techniques des éléments montrés dans ce catalogue. L'entreprise décline toute responsabilité pour d'éventuelles inexactitudes dans le présent catalogue.

Blob se reserva la facultad de modificar, en cualquier momento y sin previo aviso, las características técnicas de los elementos ilustrados en el presente catálogo. Idea srl declina toda responsabilidad por eventuales inexactitudes del mismo catálogo.

Blob оставляет за собой право без уведомления вносить в любое время изменения в технические характеристики элементов, указанных в настоящем каталоге. Компания не несет ответственности за любые неточности, содержащиеся в нем.



BLOB

Blob srl via Marigonda, 13/15
31040 Navolè di Gorgo al Monticano (TV) Italy
Tel. +39 0422 814987 Fax +39 0422 814074
www.ideagroup.it blob@ideagroup.it