

mdf italia



© COPYRIGHT 2021 MDF ITALIA SRL SOCIETA' UNIPERSONALE

2016 - 2019

TENSE MATERIAL STONE & MARBLE

Designed by Piergiorgio Cazzaniga, Michele Cazzaniga

“A smart beauty, resulting from a thought and a know-how capable of transmitting a deep emotion through a wise accentuation of the peculiarities of the materials used”. Tense Material collection is available in 5 heights and 36 sizes, 170 typologies to meet different market needs, from residential to business spaces.

Raw materials' resistance and uniqueness.

A mix of natural and industrial materials give birth to TENSE MATERIAL made of STONE: its natural and smooth surface of Pietra di Savoia features irregular shades, typical of sedimentary stones.

The reconstructed white Calce and black slate stone finishes (available from May 2021), obtained from mineral mixtures of marble and quartz, are applied by hand over the entire surface of the table, creating unique shades that are different for each table.

The material essence of the finishes is enhanced by the essentiality and linearity of Tense, characteristics that make this design icon perfect in any context and with any furnishing style.

Tense Material in the MARBLE release is developed from marble powder that, blended with a binder, is spread manually over the entire tabletop. The result is a solid and compact surface. The reconstructed marble keeps all the features of the original material, with the benefit of making the whole structure lighter. Available in two variants, black ebony and white Carrara, Tense Material in this precious finish fits into every living context, from the most classical to the most modern one, representing an alternative to classical marble tables.

Thanks to the possibility of equipping tables with the top-access, Tense Material in marble and stone are also suitable for workplaces, adapting to any office style.

[EXPLORE THE WHOLE TENSE COLLECTION](#)

FRAME AND TABLETOPS

Tables featuring mono-material finishes.

The 35mm thick tabletop is a load-bearing composite board built with an internal frame consisting of either aluminium profiles and polystyrene filler, except for the brass top which has an acrylic resin honeycomb filling covered with two outer layers of aluminum. 35x35mm steel legs with internal structural tie-rod.

RECONSTRUCTED STONE

Pietra di Savoia: made from a mixture of natural and industrial materials, reconstructed stone artificially reproduces the sedimentation of sandstone found in rivers, granting the product its characteristic appearance. Top, edges and legs lined with a sheet of material in a thickness of about 3 mm.

Reconstructed stone white Calce and black slate (available from May 2021): this particular finish is a mineral compound composed of marble and quartz. It is spread manually over the entire surface of the table, and after application a maturation process at room temperature is required. After a manual sanding process, the material is protected with a water-based nanotechnological finish. Top, edges and legs covered with the application of a thickness of about 1.5 mm of material.

RECONSTRUCTED MARBLE

Reconstructed marble is obtained from marble powder mixed with a binder. The compound thus obtained is spread onto the surface, granting the original material a more homogeneous appearance and yet preserving its natural features, such as its porosity. Top, edges and legs lined with a sheet of material in a thickness of about 3 mm.

TOP-ACCESS

The tables are also available in the version equipped with 1 or 2 top-access and under top cable tray. The metal cable trays are telescopic (H7/10 cm), to host various wiring systems, such multi-socket boxes, etc. wiring systems and electrical parts are not included. The steel cable spring (optional) can be inserted in the cable holes of the cable tray to lead the cables to the floor.

The top-access is made of aluminium (size 127x350 mm) in three versions: single lead with soft closing, double lead (optional), single lead with soft closing, with inlay in the same finish of the table.

Finishes: matt white painted for the reconstructed marble Carrara white table, matt black painted for stone table and reconstructed marble black Ebony table. It is also available in the same finish of the table, only for the stone, wood and marble versions, only for the single lead and only for the heights H73, H90 and H110.

DIMENSIONS

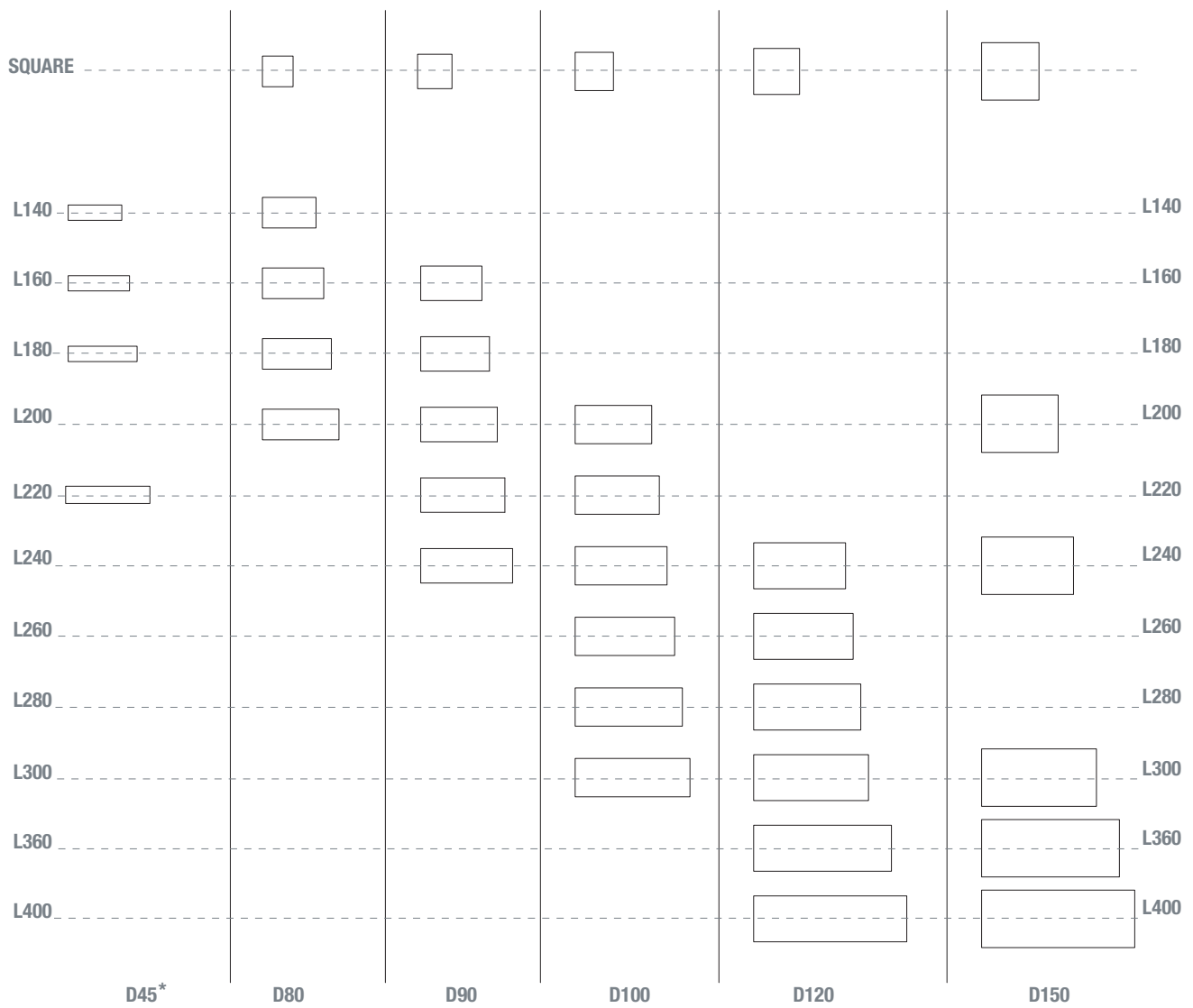
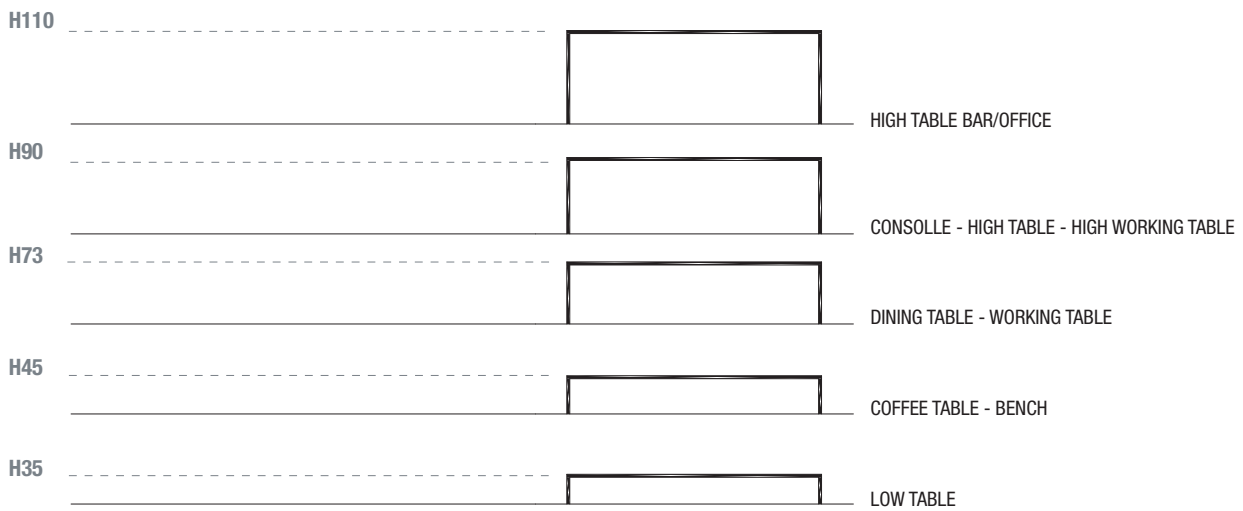

TYPE OF TOP-ACCESS L35 X H12.7 CM

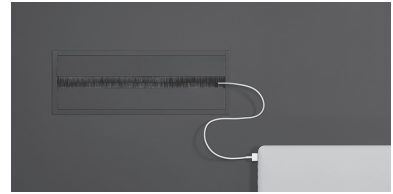
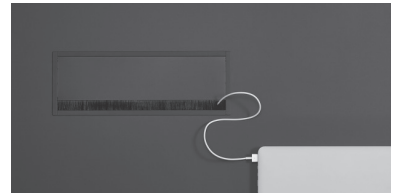
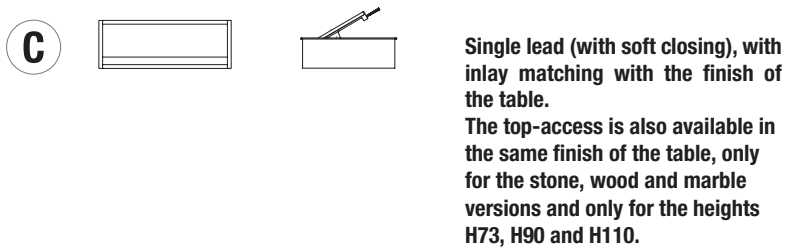
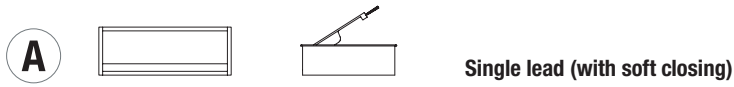

TYPE OF METAL WIREWAY (TELESCOPIC)

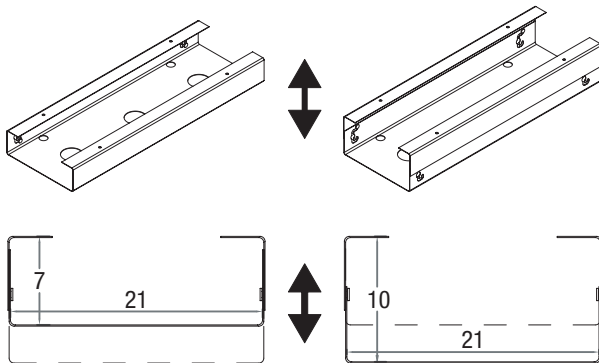

The metal cable trays are telescopic (H7/10 cm).

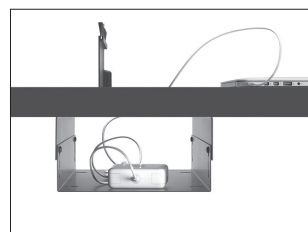
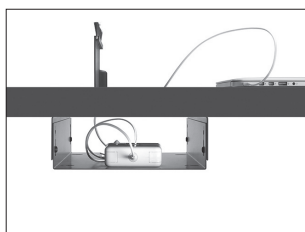

POSITION OF THE TOP-ACCESS

With one or two lateral top-access

X (cm)	Y (cm)
90	160
90	180
90	200
90	220
100	200
100	220

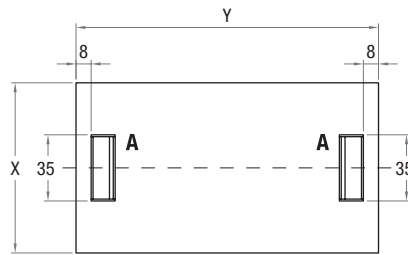

With one central top-access

X (cm)	Y (cm)
150	150
150	200
150	240

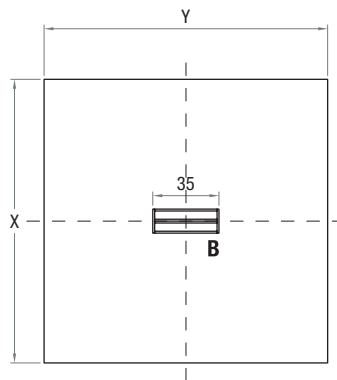

With two front top-access

X (cm)	Y (cm)	L (cm)
90	240	52
100	240	52
100	260	64
100	280	84
100	300	104
120	240	52
120	260	64
120	280	84
120	300	104
120	360	164
120	400	116

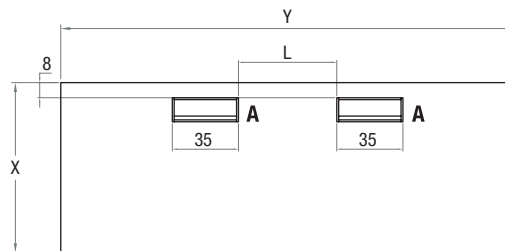

With two central top-access

X (cm)	Y (cm)	L (cm)
120	240	52
120	260	64
120	280	84
120	300	104
120	360	164
120	400	116
150	300	104
150	360	164
150	400	116

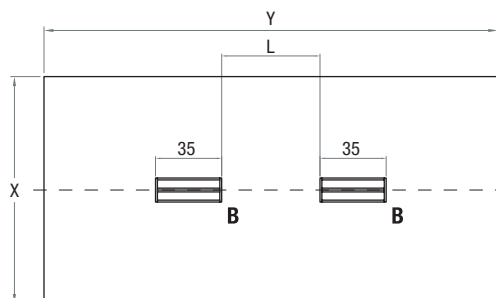

EXAMPLE OF TOP-ACCESS AND METAL WIREWAY POSITION

With one or two lateral top-access

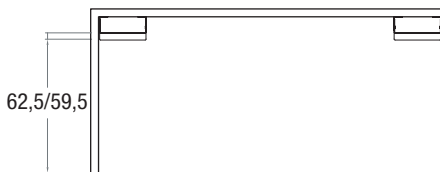
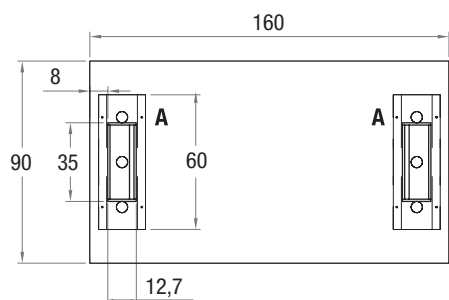

With two front top-access

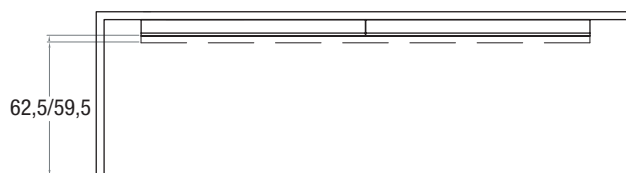
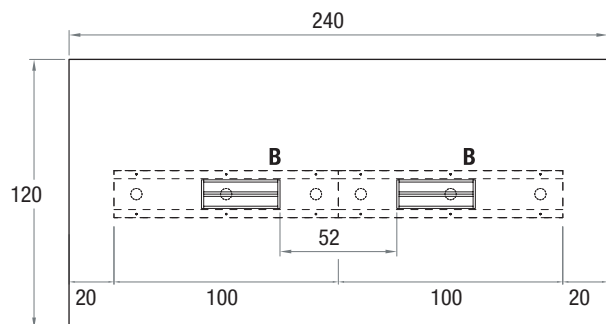

Finishing

The number in the dot corresponds to the number of colour/material finish.

Here below, in the section FINISH OPTIONS, please note all the colours of the materials used for this product.

TABLE

Top/Structure

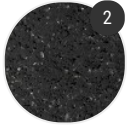

Marble



Reconstructed stone

Finish options

TOP/STRUCTURE

Marble



Reconstructed
marble white
Carrara X120



Reconstructed
marble black
ebony X111

Reconstructed stone



Reconstructed
stone white
Calce X131



Reconstructed
stone black
slate X132



Reconstructed
stone X084